

***VARIOUS
TECHNOLOGIES
INCORPORATED***

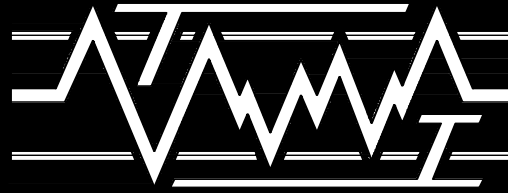

**Komand-O-Lot™
Pump Stations**

PS-1 SIMPLEX SINGLE CONTAINED PUMP STATION DATA SHEET



High Quality Sets Our Standards™

***VARIOUS TECHNOLOGIES INCORPORATED
2720 AIELLO DRIVE , BUILDINGS C/D , SAN JOSE, CA 95111
TELEPHONE (408)972-4460 FAX (408)972-4125***

Komand-O-Lot™

High Quality Sets Our Standards™

FACTORY ASSEMBLED SYSTEM - Ensures a high degree of quality control, product reliability, and product evolution. **1 YEAR FACTORY WARRANTY ON SYSTEM AS WELL AS COMPONENTS** - Our warranty covers defects in material and workmanship not just the components. See product warranty and terms and condition of sale.

PLASTIC TANKS TO ANY LENGTH AND HEIGHT - Tanks are custom fabricated to customer specification using Nitrogen or dry hot air gas welded inside and out using triangular rod, which reduces the risk of localized weld embrittlement due to overheating caused by multiple weld beads. **WELDED INLETS** - Inlets are hot gas welded into place inside and out to insure a leak tight structural pump station connection. This eliminates compatibility problems with elastomers.

WATERTIGHT CONSTRUCTION - Each pump station is manufactured to be watertight to minimize liquid overflow contamination in the event of a power failure. Water tight construction features include wet set silicone seal pump to pump mounting plate and tank lid to tank. O-ring sealed pump mounting plates and liquid level controller mounting plate. **COMPRESSION SEAL DISCHARGE AND SECONDARY CONTAINMENT INLET ON DUAL CONTAINED SYSTEMS** - An exclusive feature that allows discharge (and inlet piping on dual contained systems) to be watertight sealed while still allowing maintenance.

QUALITY CONTROL TESTING ON ALL COMPONENTS AS WELL AS THE SYSTEM - During the manufacturing phase each component is tested to insure that the highest quality is being delivered to the customer. **FACTORY BURNED IN** - As a final step in the manufacturing process, the pump station is thoroughly tested with water and run through all of its modes of operation. Further, each system is tested for overflow watertight integrity by subjecting it to a 10ft water column.

BUILT-IN INLET TURBULENCE DAMPER AND VAPOR TRAP - Eliminates up to 90% of tank inlet turbulence associated with loss of pump prime. Internal turbulence damper acts like a P-Trap. Note: This feature cannot be installed on some smaller tanks due to space limitations.

MODULAR ASSEMBLY DESIGN - Major assemblies such as the liquid level controller, pump assembly, motor starter/control panels, as well as most other options, are CNC machined to allow efficient component interchangeability. Each assembly can be removed from the

system and be disassembled into its base parts, hence reducing downtime and facility labor costs.

FACTORY WIRED FOR SINGLE POINT ELECTRICAL CONNECTION - Each station is factory color code wired to allow single point electrical connection to house power and aid in field maintenance.

SERVICEABLE ENVIRONMENTALLY SEALED DUAL CONTAINED DOUBLE TANK PUMP STATION - The outer secondary containment tank is sealed from the outside environment providing a watertight second line of defense in the event of a primary tank leak. The primary tank is bolted not welded into place, in order to allow service should it be required. Inlets through the secondary tank are compression sealed so pipe can be directly threaded into the primary holding tank. Each secondary containment tank contains an alarm switch signaling a primary tank breach. Rain water and outside liquid can't trigger false alarms.

STAINLESS STEEL FASTENERS - All screws used in construction are 316 SS when

possible corrosive exposure could occur through penetration of the primary tank lid, and 304 SS on outer flange sections.

FACTORY SUPPORT BEFORE AND AFTER THE SALE - Factory support during design phases thru installation. **OWNERS / INSTALLATION MANUALS** - Each pump station is shipped with 3 sets of manuals describing the systems operation, assembly removal and wiring instructions.

QUALITY CUSTOMS CONTROL VARIATIONS WITH FACTORY DEPENDABILITY, AND ECONOMY - Custom control schemes are available as well as modified versions of these pump station.

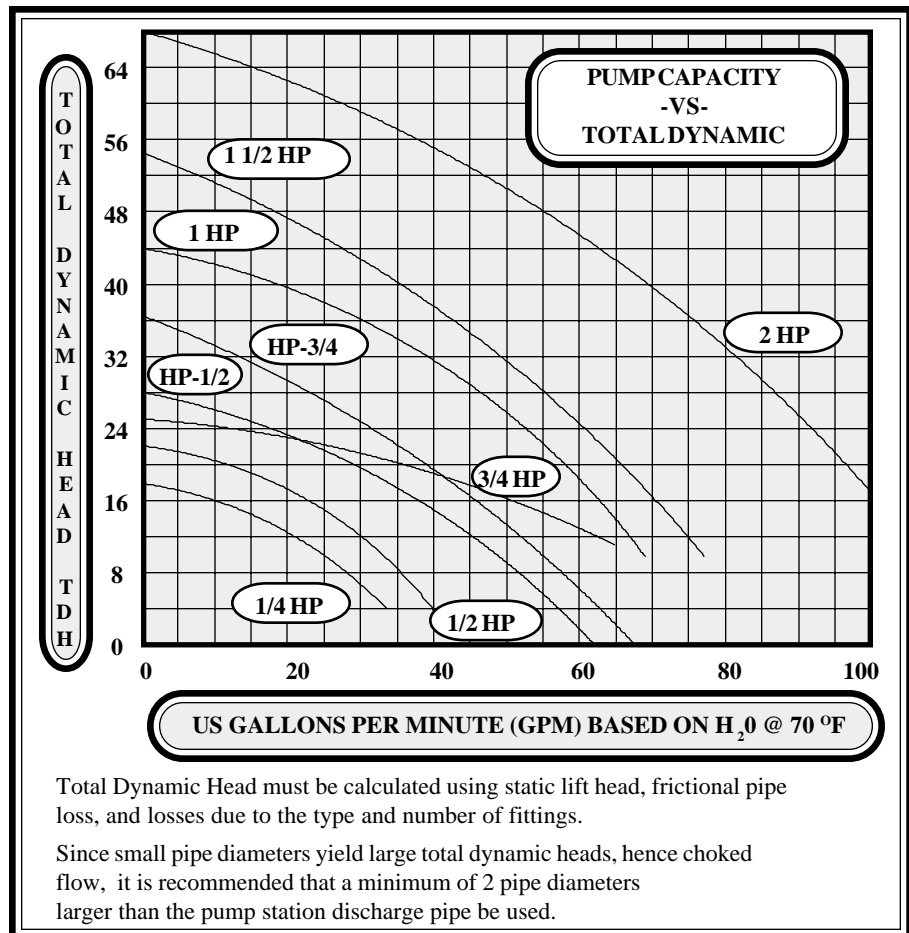

PUMP ASSEMBLY FEATURES AND BENEFITS

PUMP MOUNTING PLATE - Permits entire pump assembly removal which allows easy and fast service or replacement. The pump is wet set silicone sealed to the mounting plate.

PUMP MOTOR -Epoxy coated TEFC weather resistant motor with drip shield.

STAINLESS STEEL 316 FASTENERS - All screws on pump(s), pump platform(s), and liquid level controller mounting bracket(s) are 1/4-20 SS 316.

DISCHARGE CHECK VALVE -Diaphragm type check valve prevent liquid back flow to the pump station, while minimizing valve chatter and flow restrictions. Standard elastomer is Viton.

O-RING SEALS - Pump mounting plate is O-ring sealed to the pump station lid to help insure water tight integrity.

DISCHARGE COMPRESSION FITTING -This fitting provides a watertight seal at the discharge pipe's penetration through the pump mounting bracket. The fitting allows complete pump service without having to destroy or replace mounting components.

PLASTIC PUMP WET END - Unique sealess design in combination with it's plastic construction offers excellent corrosion resistance to many chemicals. Available in CPVC natural unfilled Polypropylene, and PVDF.

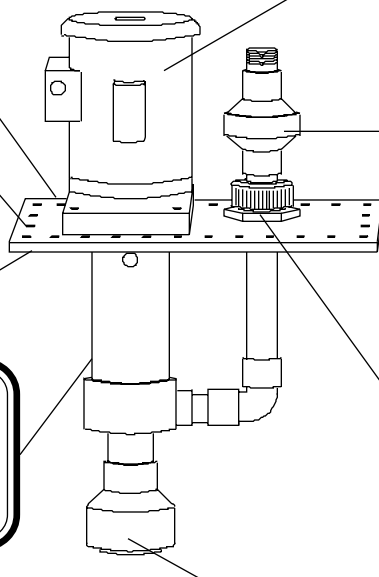

SUCTION CHECK VALVE - Suction Check maintains pump prime on tanks with a depth of 15" and greater. The check valve is specially machined to provide a low profile and prevent vortices that often are the cause of lost pump prime. Standard material is PVC in a spring check configuration. The spring is made of Stainless Steel. CPVC flapper check available upon request.

CONTROLLER FEATURES

All Plastic Construction - Polypropylene wet end material standard.

Power Interrupt Pump Down Reset - When Power is Interrupted the liquid level controller goes into the pump down mode until it reaches the low point. At the low point the liquid level controller resumes normal filling and pump down operation.

Pump Down Ground Default Interrupt - Controllers operate on 120 Vac as standard. In the event of a column leak all power is eliminated to the submersed side of the controller and it defaults to pump down.

E.P. O-Ring Sealed Mounting LC-90 thru 93 Mounting Flange

Direct Control to 1/2HP -Larger pumps and higher station voltages are controlled thru Motor starters contained within station mounted Nema 4X Control Panels. 120 Vac operation is achieved by using a voltage split on 208/230 3 phase, or via stepdown transformer for 208 polyphase and 460 Vac 3 phase.

¹ Minimum Setpoint from the Top of the Tank.

² Minimum Setpoint from the Bottom of the Tank.

STANDARD FACTORY LIQUID LEVEL CONTROLLER SETPOINTS

STANDARD CONTROL FUNCTIONS AVAILABLE	LIQUID LEVEL CONTROLLER TYPE			
	LC-90P	LC-91P	LC-92P	LC-93P
HIGH¹ LEVEL SWITCH	N/A	2" FROM TOP OF TANK	2" FROM TOP OF TANK	2" FROM TOP OF TANK
EXTRA FLOAT	NO	NO	YES	YES
HIGH PUMP LATCHING POINT¹	2" FROM TOP OF TANK	3" FROM TOP OF TANK	4.5" FROM TOP OF TANK	4.5" FROM TOP OF TANK
LOW PUMP LATCHING POINT²	3" FROM BOTTOM OF TANK	3" FROM BOTTOM OF TANK	3" FROM BOTTOM OF TANK	4.5" FROM BOTTOM OF TANK
LOW² LEVEL SWITCH	N/A	N/A	N/A	2" FROM BOTTOM OF TANK
EXTRA FLOAT	NO	NO	NO	YES

SIMPLEX SINGLE CONTAINMENT PUMP STATIONS SERIES PS-1

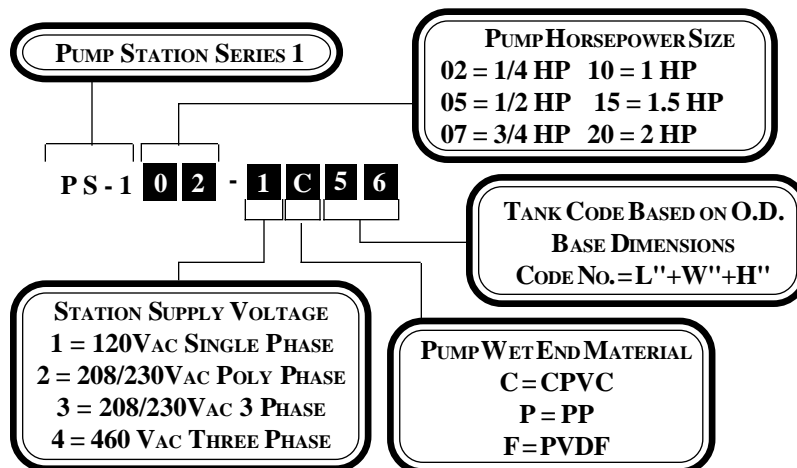
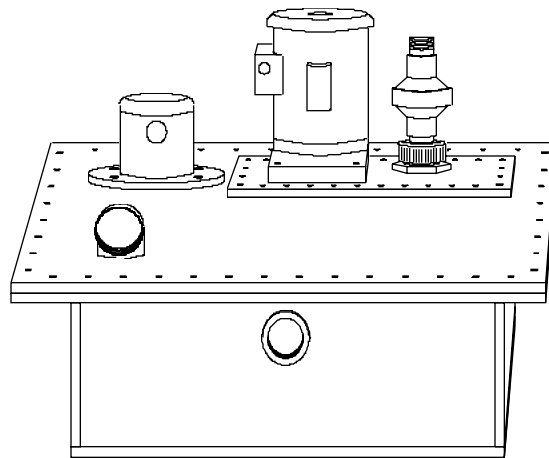

INCLUDE OD BASE DIMENSIONS (L, W, AND H) FROM CUSTOMER SUPPLIED INFORMATION CHART WITH ORDER

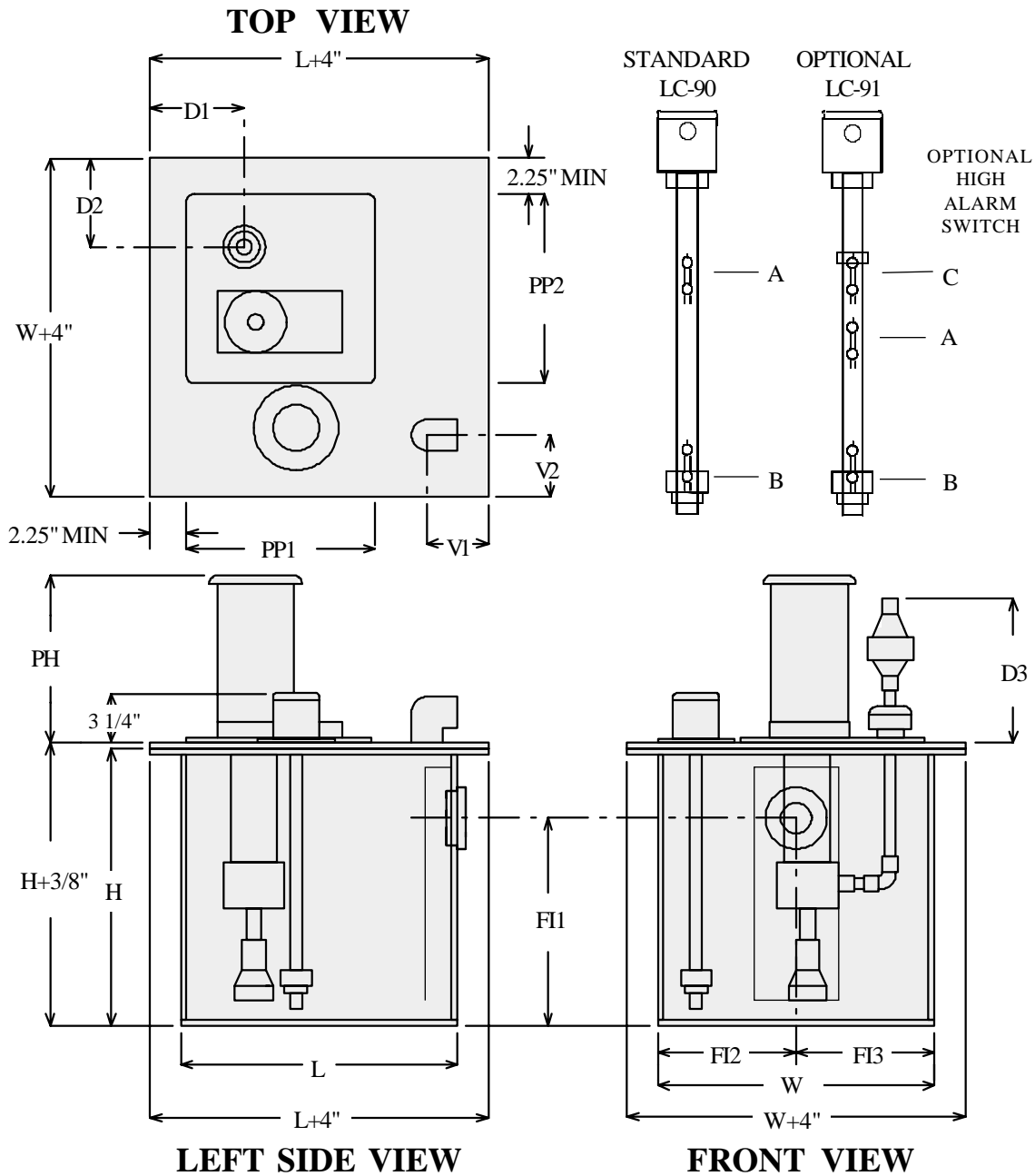

CUSTOMER SUPPLIED INFORMATION	PRIMARY ¹ TANK SIZE			INLET ² LOCATION			VENT ³ LOCATION		PUMP SELECTION	
	L	W	H	FI1	FI2	FI3	V1	V2	HPSIZE	MATERIAL
FACTORY DIMENSION	12"	12"	11"	3/4H	1/2W	1/2W	4"	4"	1/4-5	CPVC
CUSTOMER'S DIMENSION										

¹ MINIMUM TANK DIMENSIONS

CALCULATE OTHER DIMENSIONS FROM ABOVE

² INLET LOCATION

F=FRONT SIDE L=LEFT SIDE
 R=RIGHT SIDE T=TOP SIDE
 B=BACK SIDE
 MINIMUM INLET LOCATION IS 3" FROM ANY WALL.

³ VENT LOCATION - MINIMUM DIMENSION IS 4" FROM ANY SIDE.

* MINIMUM DIMENSION

PUMP PLATFORM MEASUREMENTS						
PUMP SIZE	D1*	D2*	D3*	PH	PP1	PP2
1/4HP	4.75"	5.75"	5.5"	10.75"	10"	11.5"
1/2 - 3/4 HP	6.5"	5.5"	5.75"	13"	12.75"	12.75"
1 - 2 HP	5.1"	5.75"	6"	13"	12.75"	14.75"

DISCHARGE PIPE SIZE: 1/4-1/2hp: 3/4" NPT, 3/4-1 1/2hp: 1" NPT, 2hp: 1 1/2" NPT